

**MOTOR SPEED PRODUCT LINE:
CAST IRON — MAG DRIVE PUMPS
SERIES 895**

Section	1443
Page	1443.1
Issue	E

TABLE OF CONTENTS

Features & Benefits 2
 Standard Materials of Construction 2
 Model Number Key 3
 Cutaway View & Pump Features 3
 Specifications 4
 Dimensions – GG, HJ, HL Sizes (*Unmounted*) 4
 Dimensions – GG, HJ, HL Sizes – MD-A (*B Drive*) 5
 Dimensions – HJ, HL Sizes – MD-B (*B Drive*) 5
 Dimensions – GG, HJ, HL Sizes – MD-A & MD-B (*M Drive*) 6
 Dimensions – AS, AK, AL Sizes (*Unmounted*) 6
 Dimensions – AS, AK, AL Sizes – MD-B (*M Drive*) 7
 Dimensions – AS, AK, AL Sizes – MD-B (*B Drive*) 7
 Dimensions – AS, AK, AL Sizes – MD-C80 (*B Drive*) 8
 NPSH Required 9
 Selecting the Correct Viking Mag Drive® Coupling 10
 Example 1 10
 Example 2 10

RELATED PRODUCTS

Cast Iron, 495/4195 Series: Catalog Section 1441
 Steel Externals, 893 Series Mag Drive: Catalog Section 1343
 Stainless Steel, 897 Series Mag Drive: Catalog Section 1743

SERIES DESCRIPTION

895 Series pumps are designed to provide positive displacement pumping capability in those situations that require the highest assurance of liquid containment. These mag drive pumps provide for the safe, trouble-free transfer of hazardous, EPA-regulated fluids without electronic monitoring as required with mechanical face-type shaft seals. Hard-to-seal liquids are also easily handled with the Viking Mag Drive which eliminates the high cost of mechanical seal replacement and repair. A variety of coupling sizes are available for flow requirements to 75 GPM. The torque-carrying ability of high-strength magnets allows pumps to be coupled with gear reducers for slow-speed handling of viscous liquids. The self-priming positive-displacement pumping principle provides low-shear, non-pulsing flow. Internal gear pumps are available in stainless steel, steel, and cast iron construction.

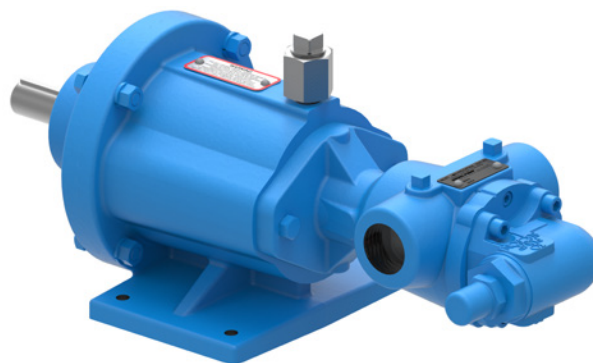

GG895
MD-B40B, bearing carrier, footed bracket,
and mounted pump with tapped ports
 (shown with optional temperature probe connection)

OPERATING RANGE

SERIES	NOMINAL FLOW		MAXIMUM PRESSURE		TEMPERATURE RANGE		VISCOSITY RANGE	
	GPM	m ³ h	PSI	Bar	°F	°C	SSU	cSt
895	7 - 75	1.6 - 17	125	8.5	-60 to +500	-50 to +260	28 to 25,000	1 to 5,500

Section	1443
Page	1443.2
Issue	E

MOTOR SPEED PRODUCT LINE: CAST IRON — MAG DRIVE PUMPS SERIES 895

FEATURES & BENEFITS

- Internal Gear
 - » With only two moving parts, Viking Mag Drive and Viking's gear-within-a-gear principle provides low-shear pumping.
- Magnetic Coupling
 - » Viking Mag Drive magnetically couples the pump to the driver. Magnetic force passing through a stainless steel canister is used to drive the inner coupling, eliminating the need for shaft seals.

STANDARD MATERIALS OF CONSTRUCTION

Component		Standard Material
Casing		Cast Iron, ASTM A48, Class 35B
Head		Cast Iron, ASTM A48, Class 35B
Idler	Standard	③ PPS Composite
	Optional	Powdered Metal, FN-0208-45 (GG) ① Powdered Metal, FC-0208-50 (HJ, HL) Ductile Iron, ASTM A536 Grade 60-40-18 (AS, AK, AL)
Rotor	Standard	Cast Iron, ASTM A48, Class 35B (GG, HJ) Ductile Iron, ASTM A536 Grade 60-40-18 (HL, AS, AK, AL)
	Optional	② Steel, ASTM A148, Grade 80-50
Rotor Shaft		Hardened Steel ASTM A108, Grade 1045
Idler Pin		Hardened Steel ASTM A108, Grade 1045
Idler & Casing Bushing	Standard	Carbon Graphite
	Optional	Hardened Cast Iron, Silicon Carbide
Internal Pressure Relief Valve		Cast Iron, ASTM A48, Class 35B
Canister		④ 316L Stainless Steel
Coupling Magnets	Standard	Neodymium Iron Boron
	Optional	Samarium Cobalt
O-rings	Standard	FKM
	Optional	PTFE (Derivative) Encapsulated, FFKM

① GG uses steel idler when steel fitted pump is required.

② Hardened steel rotor will be provided on GG & HJ sizes. GG uses steel idler when steel fitted pump is required.

③ Standard Material is Polyphenylene Sulfide with composite material. Recommend using metal idler above 10,000 SSU.

④ MD-A canisters are 316 stainless steel.

**MOTOR SPEED PRODUCT LINE:
CAST IRON — MAG DRIVE PUMPS**
SERIES 895

Section	1443
Page	1443.3
Issue	E

MODEL NUMBER KEY

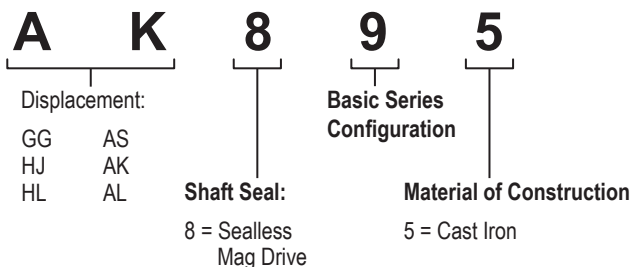

CUTAWAY VIEW & PUMP FEATURES

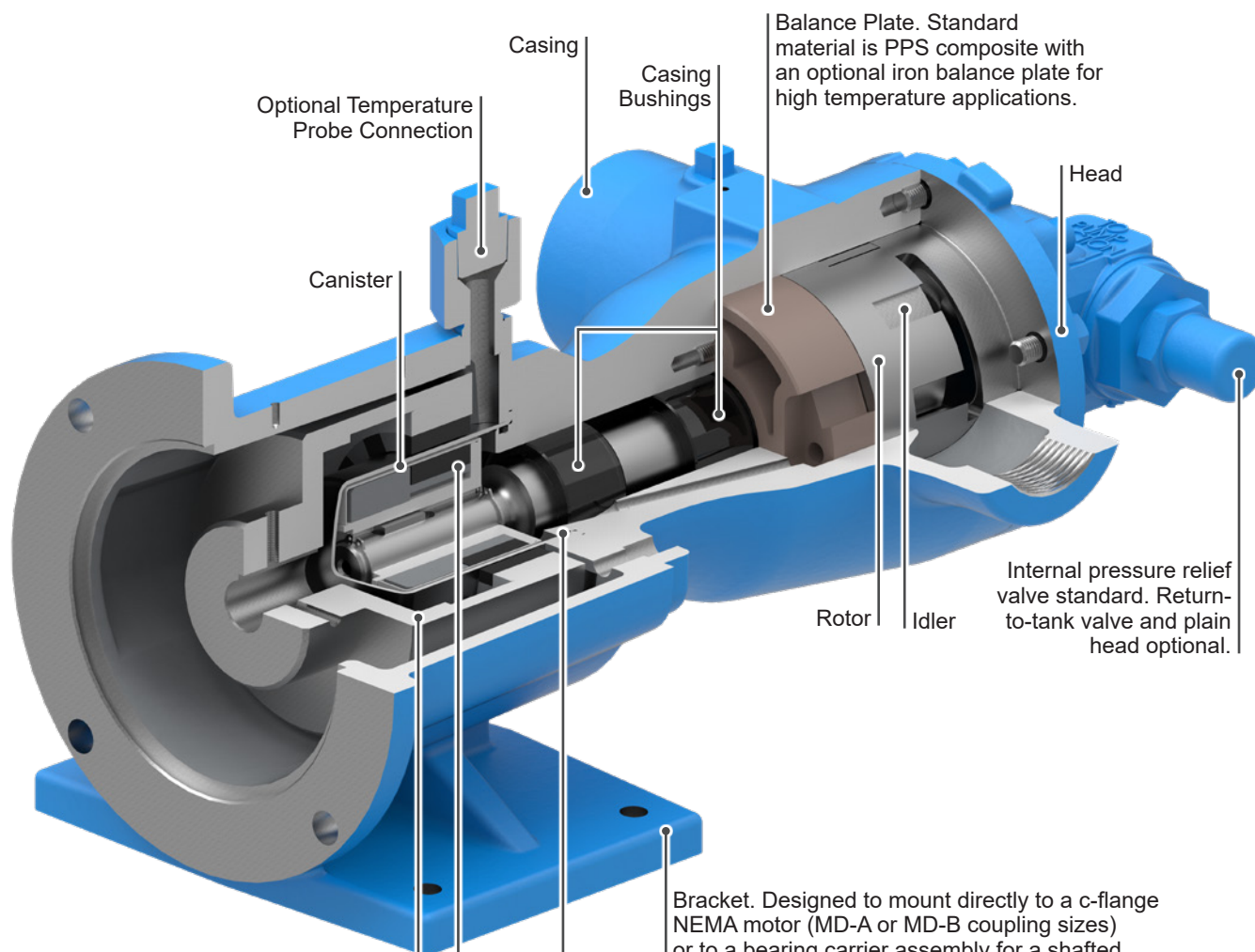

Outer Magnet Assembly. The outer magnet is the drive magnet, driven directly by the motor.

Inner Magnet Assembly. The inner magnet is the driven magnet, aligned by magnetic force passing through the canister. The inner magnet assembly is shielded in a laser welded 316SS housing to prevent exposure of the magnets to the liquid.

Canister O-Ring. Along with the canister, this static seal replaces traditional dynamic seals like packing and mechanical seals. This provides the highest assurance against leakage on difficult to seal liquids.

Section	1443
Page	1443.4
Issue	E

MOTOR SPEED PRODUCT LINE: CAST IRON — MAG DRIVE PUMPS SERIES 895

SPECIFICATIONS

Model Number	Port Size Inches	Nominal Pump Rating (100 SSU & below)			① Magnetic Coupling Availability			② Maximum Temperature		④ Maximum Hydrostatic Pressure		Approximate Pump Shipping Weight with Valve (less power)		③ Approximate Coupling Only Shipping Weight (ready to accept but less power)	
					Series	Torque		°F	°C	PSIG	BAR	Lbs.	Kg.	Lbs.	Kg.
						Ft-Lbs	Nm								
GG895	1	10	2.3	1800	MD-A	4	5.4	225	93	400	28	22	10	31	14
		7	1.6	1200		9	12.2								
HJ895	1½	20	4.5	1800	MD-A	4	5.4	225	93	400	28	30	14	31	14
		13	3	1200	MD-B	40	54								
HL895	1½	30	6.8	1800	MD-A	4	5.4	225	93	400	28	30	14	31	14
		20	4.5	1200	MD-B	40	54								
AS895	2½	35	8	1200	MD-B	40	54	225	93	400	28	78	35	71	32
					MD-C	80	108								
AK895	2½	50	11	1200	MD-B	40	54	225	93	400	28	78	35	71	32
					MD-C	80	108								
AL895	3	75	17	1200	MD-B	40	54	225	93	400	28	78	35	71	32
					MD-C	80	108								

① See Performance Curves, which can be electronically generated with the Viking Pump Curve Generator, located on www.vikingpump.com, for specific coupling recommendation on other pressures and viscosities. See page 12 for "Selecting the correct Mag Drive coupling."

② Higher temperatures can be handled with Samarium Cobalt magnets. See page 12 for torque and temperature limits.

③ For bearing carrier weights add 8 Lbs (2 Kg) for "MD-A" size, add 17 Lbs (4 Kg) for "MD-B" size.

④ Hydrostatic pressure limit is a function of ports, head gaskets, and canister ratings. Higher pressures available with special construction.

DIMENSIONS – GG, HJ, HL SIZES (UNMOUNTED)

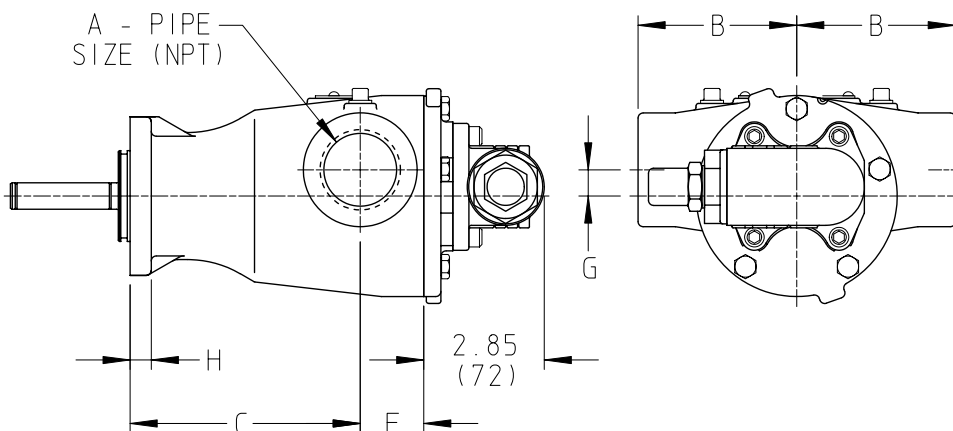

Model Number	A (in)		B	C	E	G	H
GG-895	1	in	2.75	4.29	1.12	0.62	0.50
		mm	70	108	29	16	13
HJ-895 HL-895	1½	in	3.75	5.44	1.50	0.62	0.50
		mm	95	138	38	16	13

**MOTOR SPEED PRODUCT LINE:
CAST IRON — MAG DRIVE PUMPS
SERIES 895**

Section	1443
Page	1443.5
Issue	E

DIMENSIONS – GG, HJ, HL SIZES – MD-A (B DRIVE)

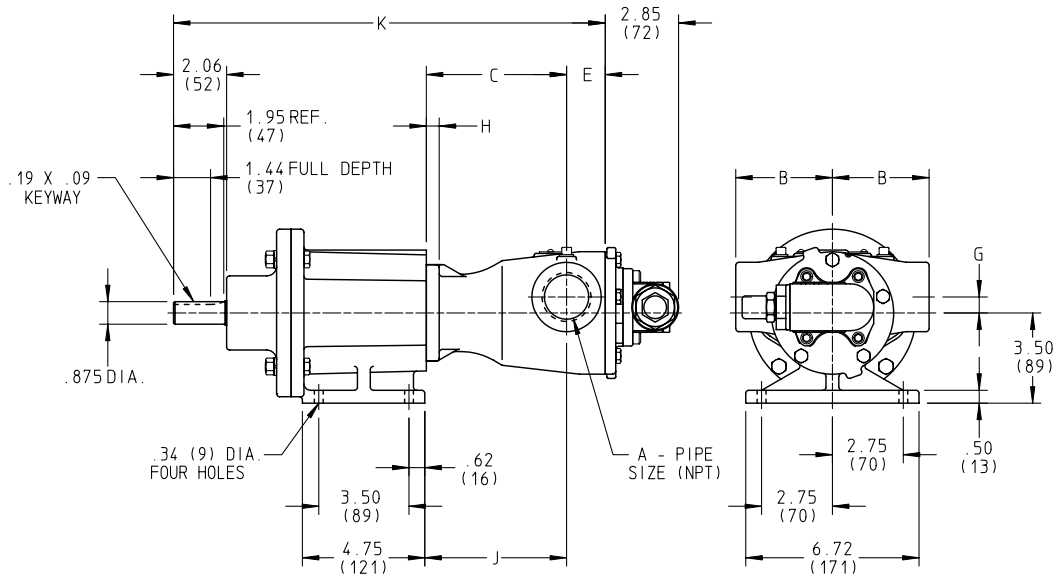

Model Number	A (in)		B	C	E	G	H	J	K
GG-895-MD-A	1	in	2.75	4.29	1.12	0.62	0.50	4.35	15.30
		mm	70	108	29	16	13	123	389
HJ-895-MD-A HL-895-MD-A	1½	in	3.75	5.44	1.50	0.62	0.50	5.50	16.75
		mm	95	138	38	16	13	140	425

DIMENSIONS – HJ, HL SIZES – MD-B (B DRIVE)

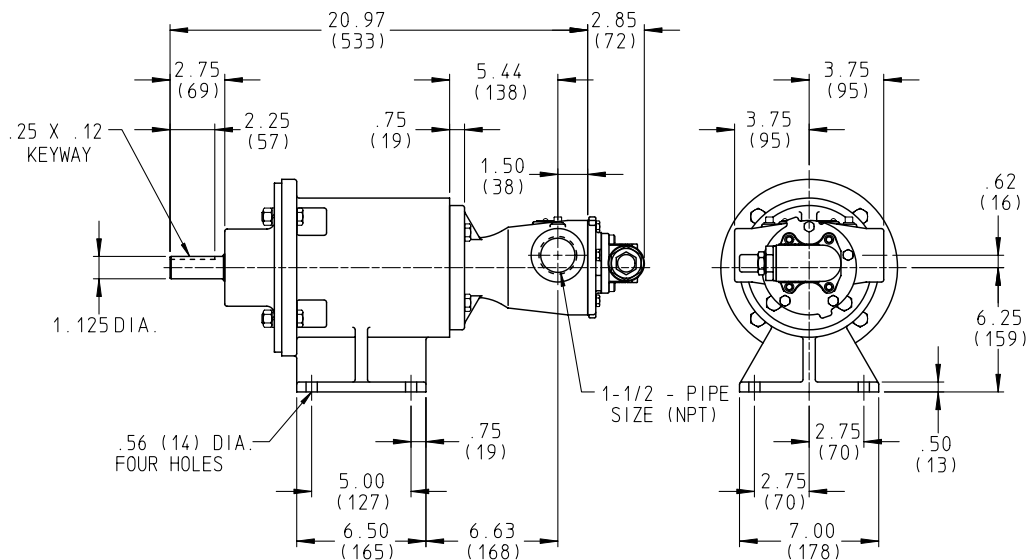

These dimensions are average and not for construction purposes. Certified prints on request.

Section	1443
Page	1443.6
Issue	E

**MOTOR SPEED PRODUCT LINE:
CAST IRON — MAG DRIVE PUMPS
SERIES 895**

DIMENSIONS – GG, HJ, HL SIZES – MD-A & MD-B (M DRIVE)

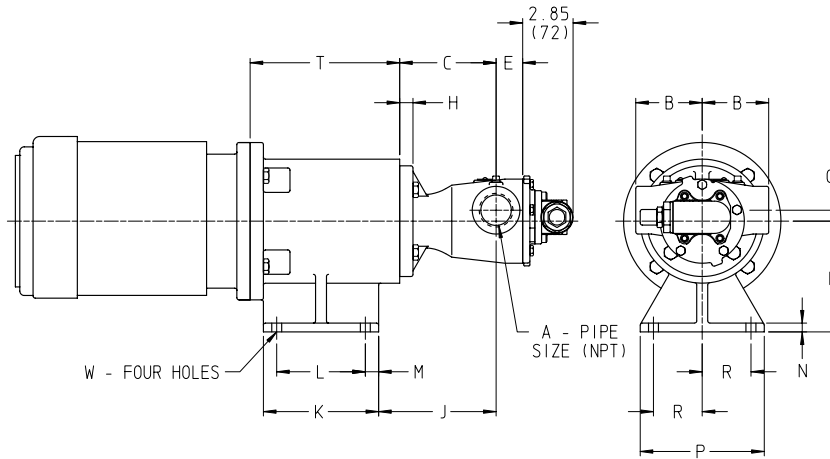

Model Number	A (in)		B	C	D	E	G	H	J	K	L	M	N	P	R	T	W
GG-895-MD-A	1	in	2.75	4.29	3.50	1.12	0.62	0.50	4.85	4.75	3.50	0.62	0.50	6.72	2.75	5.25	0.34
		mm	70	108	89	29	16	13	123	121	89	16	16	171	70	133	9
HJ-895-MD-A HL-895-MD-A	1½	in	3.75	5.44	3.50	1.50	0.62	0.50	5.50	4.75	3.50	0.62	0.50	6.72	2.75	5.25	0.34
		mm	95	138	159	38	16	13	140	121	89	16	13	171	70	133	9
HJ-895-MD-B HL-895-MD-B	1½	in	3.75	5.44	6.25	1.50	0.62	0.75	6.63	6.50	5.00	0.75	0.50	7.00	2.75	8.44	0.56
		mm	95	138	159	38	16	13	164	165	127	19	13	178	70	210	14

DIMENSIONS – AS, AK, AL SIZES (UNMOUNTED)

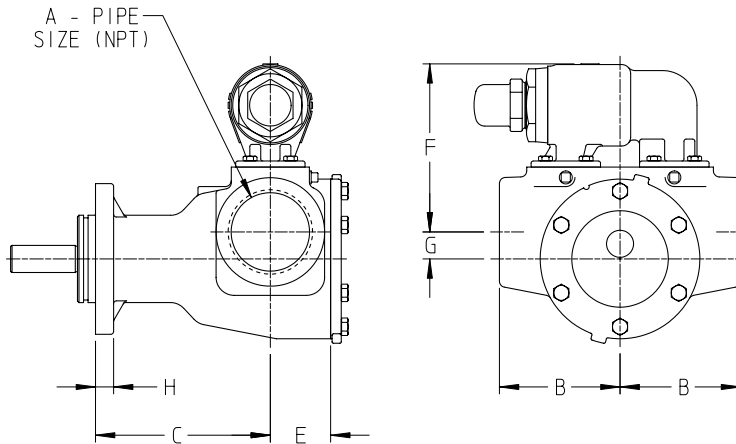

Model Number	A (in)		B	C	E	F	G	H
AS-895 AK-895	2½	in	5.00	7.50	2.00	7.00	1.12	0.75
		mm	127	190	51	178	29	19
AL-895	3	in	5.00	7.25	2.50	7.00	1.12	0.75
		mm	127	184	63	178	29	19

These dimensions are average and not for construction purposes. Certified prints on request.

**MOTOR SPEED PRODUCT LINE:
CAST IRON — MAG DRIVE PUMPS
SERIES 895**

Section	1443
Page	1443.7
Issue	E

DIMENSIONS – AS, AK, AL SIZES – MD-B (M DRIVE)

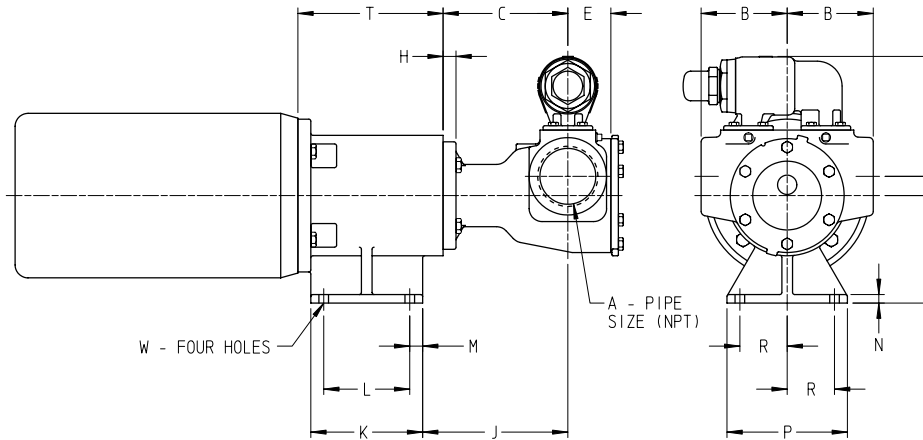

Model Number	A (in)		B	C	D	E	F	G	H	J	K	L	M	N	P	R	T	W
AS-895-MD-B AK-895-MD-B	2½	in	5.00	7.50	6.25	2.00	7.00	1.12	0.75	8.69	6.50	5.00	0.75	0.50	7.00	2.75	8.44	0.56
		mm	127	190	159	51	178	29	19	221	165	127	19	13	178	70	214	14
AL-895-MD-B	3	in	5.00	7.25	6.25	2.50	7.00	1.12	0.75	8.44	6.50	5.00	0.75	0.50	7.00	2.75	8.44	0.56
		mm	127	184	159	63	178	29	19	214	165	127	19	13	178	70	214	14

DIMENSIONS – AS, AK, AL SIZES – MD-B (B DRIVE)

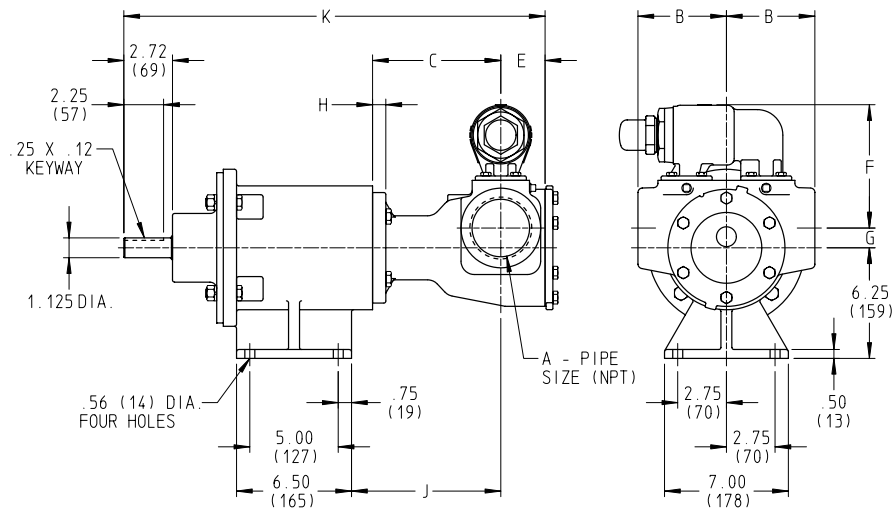

Model Number	A (in)		B	C	E	F	G	H	J	K
AS-895-MD-B AK-895-MD-B	3	in	5.00	7.50	2.00	7.00	1.12	0.75	8.69	23.53
		mm	127	190	51	178	29	19	221	598
AL-895-MD-B	3	in	5.00	7.25	2.50	7.00	1.12	0.75	8.44	23.78
		mm	127	184	63	178	29	19	14	604

These dimensions are average and not for construction purposes. Certified prints on request.

Section	1443
Page	1443.8
Issue	E

**MOTOR SPEED PRODUCT LINE:
CAST IRON — MAG DRIVE PUMPS
SERIES 895**

DIMENSIONS – AS, AK, AL SIZES – MD-C80 (B DRIVE)

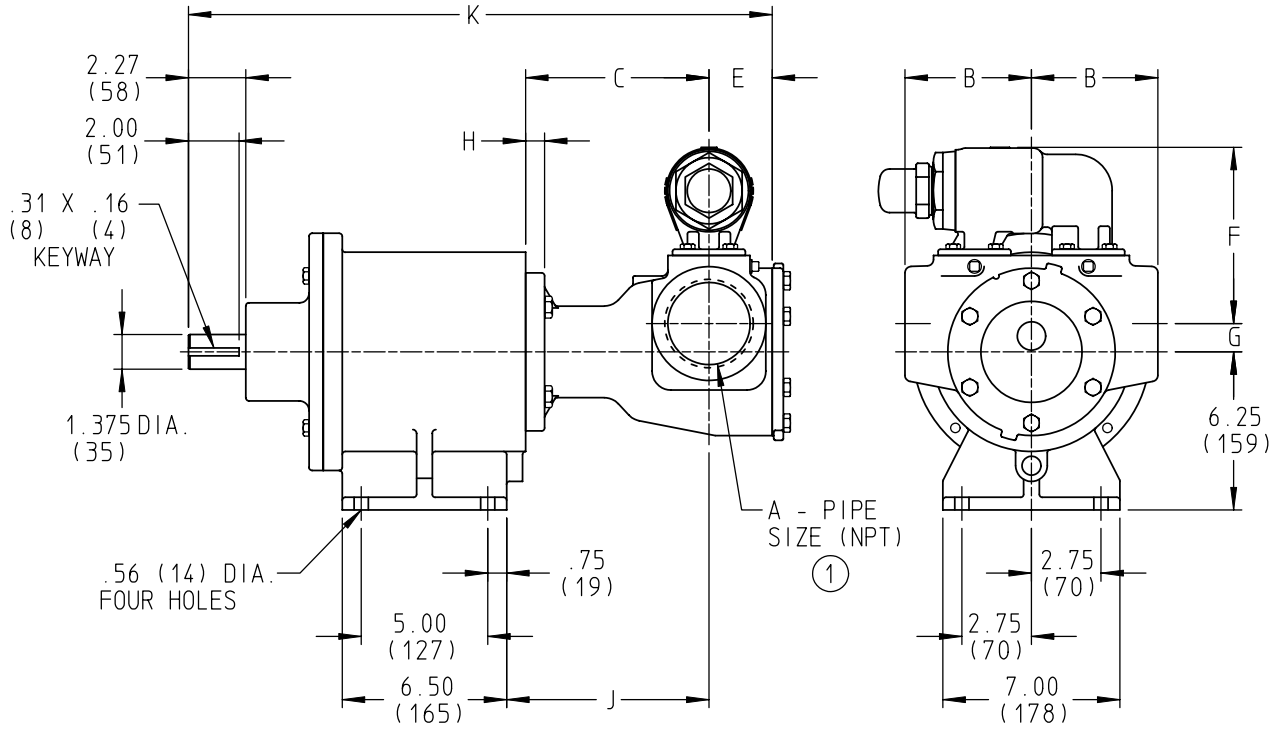

Model Number	A (in)		B	C	E	F	G	H	J	K
AS-895-MD-C AK-895-MD-C	3	in	5.00	7.50	2.00	7.00	1.12	0.75	8.25	22.83
		mm	127	190	51	178	29	19	210	580
AL-895-MD-C	3	in	5.00	7.25	2.50	7.00	1.12	0.75	8.00	23.08
		mm	127	184	63	178	29	19	203	586

These dimensions are average and not for construction purposes. Certified prints on request.

**MOTOR SPEED PRODUCT LINE:
CAST IRON — MAG DRIVE PUMPS
SERIES 895**

Section	1443
Page	1443.9
Issue	E

NPSH REQUIRED

Printed performance curves are not available.

Performance curves can be electronically generated with the Viking Pump Curve Generator on vikingpump.com.

NPSH_R data is not available on the Curve Generator.

NPSH (Net Positive Suction Head): The NPSH_R (Net Positive Suction Head Required by the pump) is given in the table below and applies for viscosities through 750 SSU. NPSH_A (Net Positive Suction Head – Available in the system) must be greater than the NPSH_R. For a complete explanation of NPSH, see Application Data Sheet AD-19.

FOR VISCOSITIES UP TO 750 SSU – See NPSH_R table below.

NPSH_R for high viscosities can be estimated using the following method:

1. Calculate line loss for a 1 foot long pipe of a diameter matching the pump inlet port size. Use your flow rate and max viscosity.
2. Convert this value into Feet of Liquid (S.G. 1.0)
3. Add this value to the NPSH_R value in the chart below.

NPSH_R – FEET OF LIQUID (Specific Gravity 1.0), Viscosities up to 750 SSU

PUMP SIZE	PUMPS SPEED, RPM					
	840	780	950	1150	1450	1750
GG	2.2	2.6	3.1	3.9	5.6	7.6
HJ, HL	2.8	3.4	4.5	6.2	9.5	13.5
AS, AK, AL	3.9	5.5	7.7	11.2	—	—

Section	1443
Page	1443.10
Issue	E

MOTOR SPEED PRODUCT LINE: CAST IRON — MAG DRIVE PUMPS SERIES 895

SELECTING THE CORRECT VIKING MAG DRIVE® COUPLING

1. Find pump HP and speed from the performance curves, which can be electronically generated with the Viking Pump Selector Program, located on www.vikingpump.com/pumpselector.

2. Calculate the application torque (T), using this formula:

$$T \text{ (FT-LB)} = \frac{\text{HP}}{\text{SPEED}} \times 5252$$

3. Select the temperature correction factor (TCF) from Table 1 or Table 2.

STANDARD NEODYMIUM MAGNETS (For Application Temperatures Below 225°F.)							
Application Temp. (°F)	AMB	100	125	150	175	200	225
TCF	1.0	.94	.88	.82	.76	.70	.64

Table 1: Temperature Correction Factors

OPTIONAL SAMARIUM COBALT MAGNETS (For Application Temperatures Above 225°F.)					
Application Temp. (°F)	175	200	300	400	500
TCF	.74	.73	.69	.63	.59

Table 2: Temperature Correction Factors

4. Divide calculated application torque by TCF to get adjusted application torque.

5. Select coupling with rating equal to or greater than “adjusted application torque” from Table 3.

MAGNETIC COUPLING TORQUE RATING TABLE	
Coupling Size	Torque (FT-LBS)
MD-A4	4
MD-A9	9
MD-B40	40
MD-C80	80

Table 3

EXAMPLE 1

1. A GG895 is required to pump 100 SSU liquid at 1750 RPM, 50 PSI differential pressure.

Temperature is 100°F.

From the pump selector, required HP is 0.85.

2. Calculate torque (T).

$$\begin{aligned} \text{TORQUE (T)} &= \frac{0.85}{1750} \times 5252 \\ &= 2.6 \text{ FT-LB} \end{aligned}$$

3. From the temperature correction factor table, the correction factor (TCF) = 0.94.

4. Calculate adjusted application torque.

$$\begin{aligned} \text{ADJUSTED APPLICATION TORQUE} &= \frac{2.6}{0.94} \\ &= 2.8 \text{ FT-LB} \end{aligned}$$

5. Select coupling.

A STANDARD NEODYMIUM MD-A4 COUPLING IS THE PROPER SELECTION

EXAMPLE 2

1. AN AL895 is required to pump 38 SSU liquid at 1150 RPM, 50 PSI differential pressure.

Temperature is 300°F.

From the pump selector, required HP is 3.7.

2. Calculate torque (T).

$$\begin{aligned} \text{TORQUE (T)} &= \frac{3.7}{1150} \times 5252 \\ &= 16.9 \text{ FT-LB} \end{aligned}$$

3. From the temperature correction factor table, the correction factor (TCF) = 0.69.

4. Calculate adjusted application torque.

$$\begin{aligned} \text{ADJUSTED APPLICATION TORQUE} &= \frac{16.9}{0.69} \\ &= 24.5 \text{ FT-LB} \end{aligned}$$

5. Select coupling.

AN MD-B40 WITH OPTIONAL SAMARIUM COBALT MAGNETS IS THE PROPER SELECTION