

UNIVERSAL PRODUCT LINE: CAST IRON — NON-JACKETED PUMPS

124A Series™, 124AE Series™, 1124A Series™, 1124AE Series™, 4124A Series™, 4124AE Series™, 4124B Series™, 324A Series™, 1324A Series™, 4324A Series™

Section	1401
Page	1401.1
Issue	F

TABLE OF CONTENTS

Related Products	1
Operating Range.....	1
Series Description	1
Features & Benefits	2
Port Location Options	2
Model Number Key	2
Standard Materials of Construction	3
Cutaway View & Pump Features (124A Series™, 124AE Series™, 1124 Series™, 1124AE Series™, 4124A Series™, 4124AE Series™, 324A Series™, 1324A Series™, 4324A Series™)	4
Cutaway View & Pump Features (4124B Series™).....	5
Special Materials & Options Selection Guidelines	6
Specifications – G, H, HL, AK, AL, K, KK, L Sizes.....	7
Specifications – LQ, LL, LS, Q, QS, M, N, R, RS Sizes.....	8
Optional Casings.....	9
Dimensions – G, H, HL, AK, AL, K, KK, L, LQ, LL, LS, Q, M Sizes.....	10
Dimensions – G, H, HL, AK, AL, K, KK, L, LQ, LL, LS, Q, M Sizes (Cont'd)	11
Dimensions – QS Size.....	12
Dimensions – N, R, RS Sizes – Jacketed Bracket (324A Series™, 1324A Series™, 4324A Series™)	13
Dimensions – Stuffing Box Seal Chamber (Except 4124B Series™)	14
NPSH Required	15

RELATED PRODUCTS

Cast Iron, Jacketed Pumps: Catalog Section 1402
 Cast Iron, Mag Drive Pumps: Catalog Section 1403
 Steel Externals, Non-Jacketed Pumps: Catalog Section 1301
 Stainless Steel, Non-Jacketed Pumps: Catalog Section 1701

SERIES DESCRIPTION

124A Series™, 124AE Series™, 4124A Series™, 4124AE Series™, 324A Series™, 4324A Series™:

The Universal Product Line has the broadest range of sealing options of all pumps built by Viking. The stuffing box on all sizes accepts packing, numerous component single mechanical seals, or a wide variety of cartridge seals.

The Universal Product Line is Viking Pump's most versatile line of internal gear pumps due to the availability of many design and material options.

4124B Series™:

The 4124B series heavy duty internal gear pumps have Behind the Rotor dynamic shaft seals. By locating the mechanical seal immediately behind the rotor, this prevents the shaft and bracket bushing from coming into contact with the liquid.

1124A Series™, 1124AE Series™, 1324A Series™:

Viking Pump is the leader in internal gear innovation and the latest development is the O-Pro™ Seal technology. The NEW Universal Seal Product Line comes with the O-Pro Barrier Seal factory installed. The Universal Product Line combines the tested reliability of the Universal pump & O-rings to create a robust seal and lubrication chamber, all in one.



OPERATING RANGE

SERIES	NOMINAL FLOW		MAXIMUM PRESSURE		TEMPERATURE RANGE		VISCOSITY RANGE	
	GPM	m³h	PSI	Bar	°F	°C	SSU	cSt
124A Series™ 124AE Series™ **	8 - 500	1.8 - 114	200	14	-60 to +450	-50 to +230	28 to 2,000,000	0.1 to 440,000
1124A Series™ 1124AE Series™ **	8 - 400	1.8 - 91	200	14	0 to +225*	-15 to +105*	100 to 2,500*	20 to 550*
4124A Series™ 4124AE Series™ **	8 - 500	1.8 - 114	200	14	-60 to +450	-50 to +230	28 to 2,000,000	0.1 to 440,000
4124B Series™	8 - 500	1.8 - 114	200	14	-60 to +450	-50 to +230	28 to 15,000	0.1 to 3,300
324A Series™	600 - 1,600	136 - 364	200	14	-60 to +450	-50 to +230	28 to 2,000,000	0.1 to 440,000
1324A Series™	500 - 1,300	136 - 295	200	14	0 to +225*	-15 to +105*	100 to 750*	20 to 165*
4324A Series™	600 - 1,600	136 - 364	200	14	-60 to +450	-50 to +230	28 to 2,000,000	0.1 to 440,000

* Range may increase with end clearance adjustment. ** AE available in sizes L, LQ, LL only.

Section	1401
Page	1401.2
Issue	F

UNIVERSAL PRODUCT LINE: CAST IRON — NON-JACKETED PUMPS

124A Series™, 124AE Series™, 1124A Series™, 1124AE Series™, 4124A Series™, 4124AE Series™, 4124B Series™, 324A Series™, 1324A Series™, 4324A Series™

FEATURES & BENEFITS

- Positive Displacement Internal Gear pumping principle handles a broad range of viscosities with constant flow rate
- Axial rotor thrust is controlled by double row ball bearing or tapered roller bearings; a bushing provides a secondary point of radial shaft support
- Rotatable bearing housing provides easy rotor end clearance adjustment for viscosity or to compensate wear
- Numerous material options are available for bushings, idler pins, shafts, rotors, idlers and elastomers
- Gear and pump geometry has been optimized based on more than 100 years of experience
- Footed cast iron bracket provides rigid mounting to help maintain alignment, which extends seal and bearing life
- Can use direct drive, gear reducer or gearmotor drive, or belt-drive
- Pressure relief valve standard on all except RS size pumps; less valve / plain head option available



For warranty details, please go to:
vikingpump.com/warranty#information

124A Series™, 124AE Series™, 1124A Series™, 1124AE Series™, 4124A Series™, 4124AE Series™, 324A Series™, 1324A Series™, 4324A Series™ Only:

- Series designed with an enlarged bearing housing. Used in conjunction with a spacer coupling permits easy cartridge seal or O-Pro™ Barrier Seal installation and removal in place without removing the head and rotor/shaft.
- Seal options include packing, O-Pro™ Barrier Seal, single component seals, cartridge lip seals and cartridge single and double mechanical seals. Various seal flush plans are available.

PORT LOCATION OPTIONS

90° Port Options:

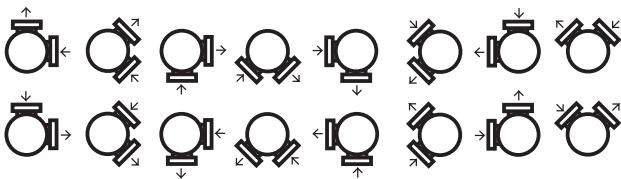

Opposite Port Options:

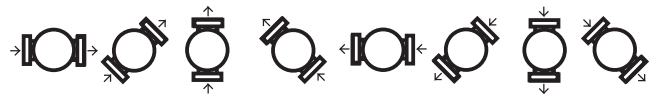

NOTE: See page 1401.9 for a complete list of casing options by size.

MODEL NUMBER KEY

L	Q	4	1	2	4	A	E
Size:		Shaft Seal:	Basic Series Configuration		Material of Construction:	Primary Shaft Diameter	
G	LL		Jacketing:	4 = Cast Iron		(L, LQ and LL Sizes in Cast Iron Only):	
H	LS	1 = No Jacketing			Blank = 1-7/16"		
HL	Q	3* = Foot Mount Casing w/ Jacketed Bracket	Seal Location:		E = 1-5/8"		
AK	QS		A = Stuffing Box Seal	(See dimension drawings for shaft diameter at coupling)			
AL	M		B = Behind the Rotor				
K	N						
KK	R						
L	RS						
LQ							

* Note: Only the N, R & RS sizes are foot mount casing with jacketed bracket.

UNIVERSAL PRODUCT LINE: CAST IRON — NON-JACKETED PUMPS

124A Series™, 124AE Series™, 1124A Series™, 1124AE Series™, 4124A Series™, 4124AE Series™, 4124B Series™, 324A Series™, 1324A Series™, 4324A Series™

Section	1401
Page	1401.3
Issue	F

STANDARD MATERIALS OF CONSTRUCTION

Component	Standard Material	
Casing	Cast Iron, ASTM A48, Class 35B	
Head	Cast Iron, ASTM A48, Class 35B	
Bracket	Cast Iron, ASTM A48, Class 35B	
Idler	Standard	① Cast Iron, ASTM A48, Class 35B
	Steel Fitted	①② Cast Iron, ASTM A48, Class 35B
Rotor	Standard	③ Cast Iron, ASTM A48, Class 35B
	Steel Fitted	④ Steel, ASTM A148, Grade 80-40
Shaft	⑤ Steel, ASTM A108, Grade 1045	
Idler Pin	Hardened Steel, ASTM A108, Grade 1045	
Idler Bushing	(4124A Series™, 4124AE Series™, 4324A Series™, 4124B Series™)	Carbon Graphite
	(1124A Series™, 1124AE Series™, 1324A Series™)	Hardened Cast Iron
	(124A Series™, 124AE Series™, 324A Series™)	Bronze, ASTM B584 (B505), Alloy C93700
Bracket Bushing (no product contact on 4124B Series™) <i>(Note: not applicable on 1124A Series™, 1124AE Series™ or 1324A Series™)</i>	(4124A Series™, 4124AE Series™, 4324A Series™)	Carbon Graphite
	(124A Series™, 124AE Series™, 324A Series™, 4124B Series™)	Bronze, ASTM B584 (B505), Alloy C93700
Pressure Relief Valve	⑥ Cast Iron, ASTM A48, Class 35B	
Standard Packing (124A Series™, 124AE Series™, 324A Series™)	Braided PTFE	
O-Pro™ Barrier Seal (1124A Series™, 1124AE Series™ or 1324A Series™)	Hardened Cast Iron, Sanitary FKM Elastomers	
Standard Mechanical Seal (4124A Series™, 4124AE Series™, 4124B Series™, 4324A Series™)	Carbon vs. Silicon Carbide Faces, FKM Elastomers	
Optional Abrasive Liquid Seal (4124B Series™)	Silicon Carbide vs. Silicon Carbide Faces, FKM Elastomers	

- ① G, H and HL sizes have a powdered metal idler: Powdered Metal MPIF 35, FC-0208-45 (G) , Powdered Metal MPIF 35, FC-0208-50 (H, HL)
- ② Q and QS sizes have a hardened steel idler when pump is steel fitted: ASTM A148 Grade 80-40.
- ③ AK, KK, LS, QS, N and RS sizes have ductile iron rotor: ASTM A536 Grade 60-40-18.
- ④ Material specification for HL steel rotor is AISI 8620, LS steel rotor is ASTM A148 80-50.
- ⑤ AK, AL, K, KK, L, LQ, LL and LS sizes, including “A”, “AE”, and “B” models, are high strength steel ASTM A434 Type 4140 Grade BC or equivalent.
- ⑥ RS relief valve not available. Contact factory for options.

Section	1401
Page	1401.4
Issue	F

UNIVERSAL PRODUCT LINE: CAST IRON — NON-JACKETED PUMPS

124A Series™, 124AE Series™, 1124A Series™, 1124AE Series™, 4124A Series™, 4124AE Series™, 4124B Series™, 324A Series™, 1324A Series™, 4324A Series™

CUTAWAY VIEW & PUMP FEATURES (124A SERIES™, 124AE SERIES™, 1124 SERIES™, 1124AE SERIES™, 4124A SERIES™, 4124AE SERIES™, 324A SERIES™, 1324A SERIES™, 4324A SERIES™)

Packing

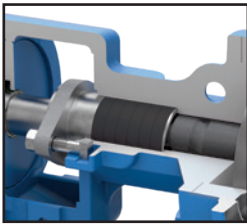

O-Pro™ Barrier Seal

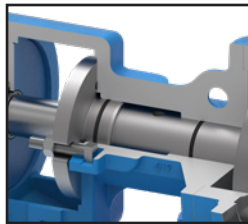

Component Seal

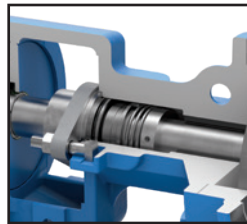

Cartridge Seal

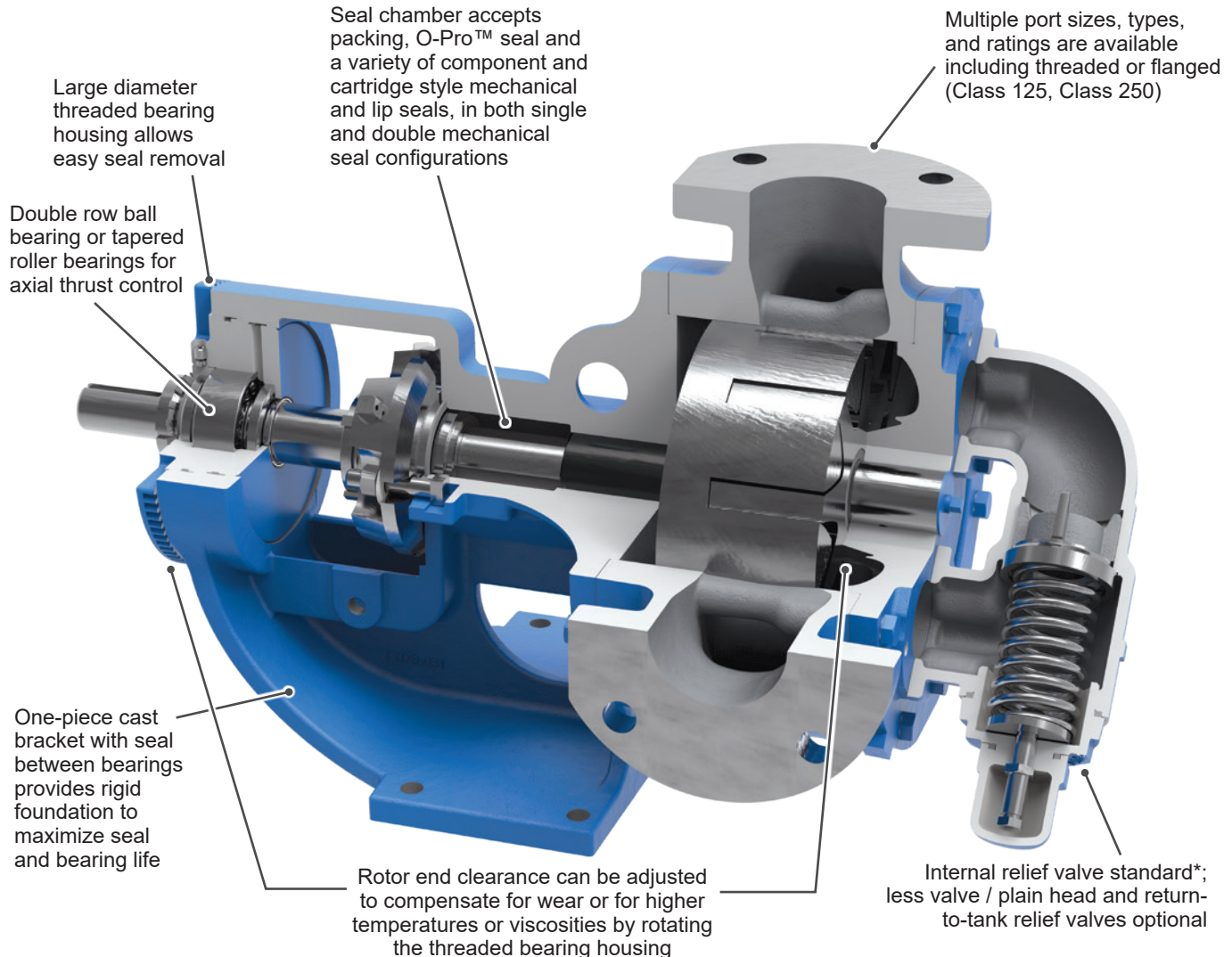
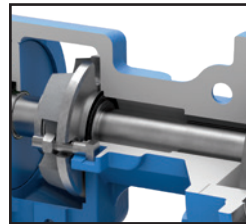

* All except RS size

UNIVERSAL PRODUCT LINE: CAST IRON — NON-JACKETED PUMPS

124A Series™, 124AE Series™, 1124A Series™, 1124AE Series™, 4124A Series™, 4124AE Series™, 4124B Series™, 324A Series™, 1324A Series™, 4324A Series™

Section	1401
Page	1401.5
Issue	F

CUTAWAY VIEW & PUMP FEATURES (4124B SERIES™)

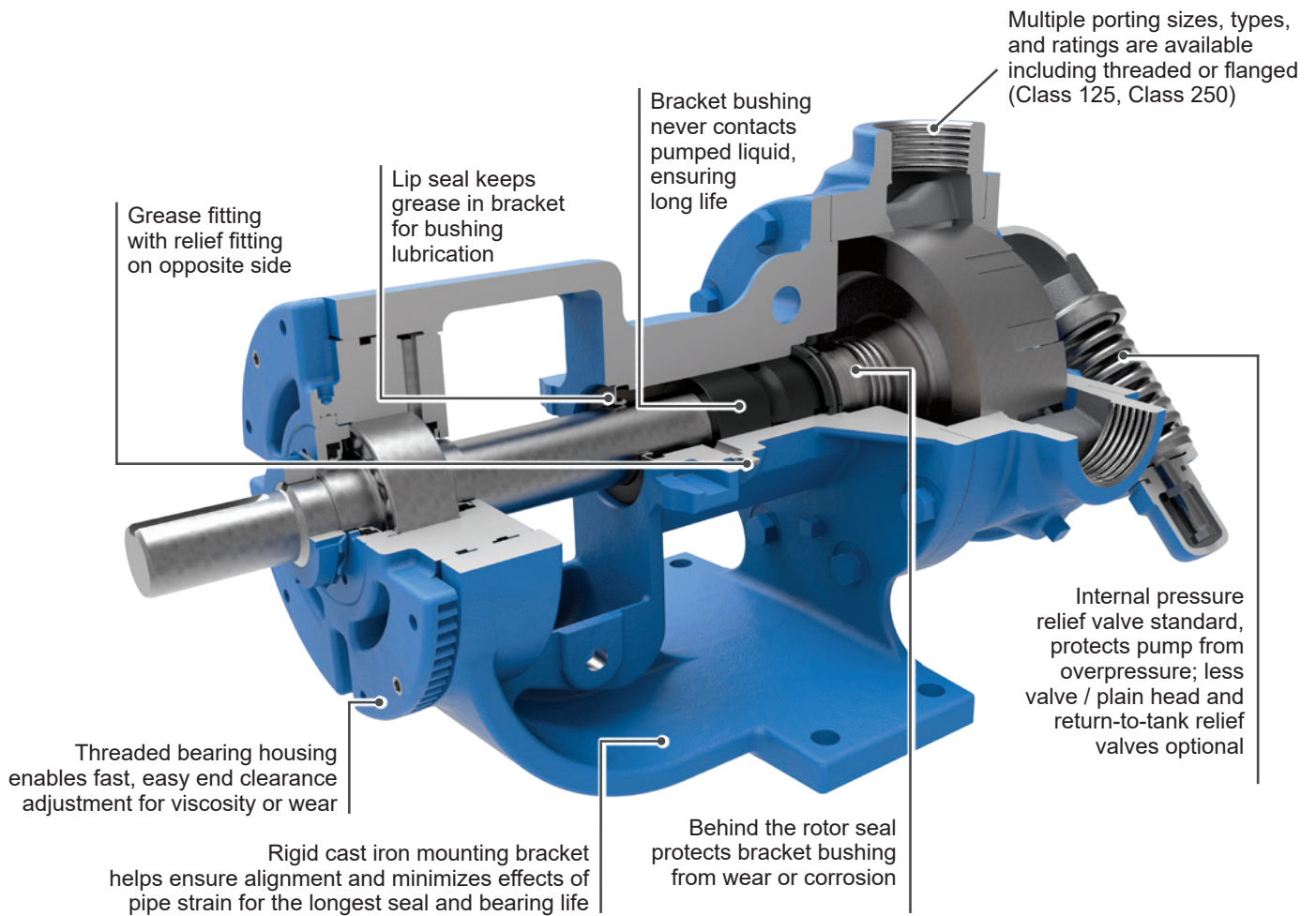

Section	1401
Page	1401.6
Issue	F

UNIVERSAL PRODUCT LINE: CAST IRON — NON-JACKETED PUMPS

124A Series™, 124AE Series™, 1124A Series™, 1124AE Series™, 4124A Series™, 4124AE Series™, 4124B Series™, 324A Series™, 1324A Series™, 4324A Series™

SPECIAL MATERIALS & OPTIONS SELECTION GUIDELINES

For High Viscosities – Above 2,500 SSU (550 cSt)

- Steel fitted construction recommended above the following viscosities, according to pump size:

Viscosity	Pump Size																
	G	H	HL	AK	AL	K	KK	L	LQ	LL	LS	Q	QS	M	N	R	RS
SSU	7,500	25,000	7,500	25,000	25,000	25,000	75,000	25,000	25,000	2,500	75,000	7,500	75,000	25,000	75,000	25,000	75,000
cSt	1,700	5,500	1,700	5,500	5,500	5,500	17,000	5,500	5,500	550	17,000	1,700	17,000	5,500	17,000	5,500	17,000

- Extra clearances, depending on viscosity. See ES-2 for recommendations.
 - » 1124A Series™, 1124AE Series™ & 1324A Series™ pumps only available with standard clearance.
- Special Sealing:
 - FKM or Buna N Type 1 component seals good up to 15,000 SSU (3,300 cSt).
 - PTFE Type 9 seals good up to 25,000 SSU (5,500 cSt).
 - Packed gland good up to 2,000,000 SSU (440,000 cSt).
 - Cartridge triple lip seals available to 2,000,000 SSU (440,000 cSt).
- Larger ports may be required depending on suction conditions.
- Pump should be operated at slower than normal speeds, which may require a larger pump.
- For viscosities over 250,000 SSU (55,000 cSt), contact factory for additional pump construction and operation recommendations.

For low viscosities or non-lubricating liquids – Below 100 SSU (20 cSt)

- Carbon graphite bushings.
- Pump should be operated at slower than normal speeds, which may require a larger pump.

For high temperatures – Above 225°F (105°C)

- High temperature elastomers – FKM up to 350°F (175°C); Buna up to 225°F (105°C); PTFE up to 450°F (230°C);
- High temperature bushings recommended depending on temperature, size and specific material. See ESB-3 for recommendations.
- Additional operating clearances may be required depending on temperature, size and specific material. See ES-2 for recommendations.
 - » 1124A Series™, 1124AE Series™ & 1324A Series™ pumps only available with standard clearance.
- For temperatures above 450°F (230°C), special materials and sealing requirements may be needed. Contact factory for recommendations.
- Pump should be operated at slower than normal speeds, which may require a larger pump.

For abrasive or dirty liquids

- If possible, filter or strain out the abrasives present.
- Wear resistant bushings - hardened cast iron, tungsten carbide or Colmonoy coated.
- Abrasive-resistant idler pin - tungsten carbide or Colmonoy plus TC filler coated pins.
- Hardened or hard-coated shaft.
- Abrasive-resistant seals.
- For high concentrations of abrasives or particle sizes greater than 250 microns (0.010 in), contact factory for recommendations.
- Pump should be operated at slower than normal speeds, which may require a larger pump.
- Consult factory for specific recommendations.

UNIVERSAL PRODUCT LINE: CAST IRON — NON-JACKETED PUMPS

124A Series™, 124AE Series™, 1124A Series™, 1124AE Series™, 4124A Series™, 4124AE Series™, 4124B Series™, 324A Series™, 1324A Series™, 4324A Series™

Section	1401
Page	1401.7
Issue	F

SPECIFICATIONS – G, H, HL, AK, AL, K, KK, L SIZES

Model Number	③ Standard NPT Port Size	Nominal Pump Rating (100 SSU & below)			④ Maximum Hydrostatic Pressure		① Maximum Discharge Pressure		② Maximum Recommended Temperature for Standard Pump		Approx. Shipping Weight with Valve	
	Inches	GPM	m ³ /h	RPM	PSIG	BAR	PSIG	BAR	°F	°C	Lbs.	Kg.
G124A	1	8	1.8	1750	400	28	200	14	450	230	25	11
G4124A	1	8	1.8	1750	400	28	200	14	350	175	25	11
G4124B	1	8	1.8	1750	400	28	200	14	350	175	22	10
H124A	1 ½	15	3.5	1750	400	28	200	14	450	230	38	17
H1124A	1 ½	8	1.8	1000	400	28	200	14	225	105	40	18
H4124A	1 ½	15	3.5	1750	400	28	200	14	350	175	38	17
H4124B	1 ½	15	3.5	1750	400	28	200	14	350	175	38	17
HL124A	1 ½	30	7	1750	400	28	200	14	450	230	40	18
HL1124A	1 ½	18	4	1000	400	28	200	14	225	105	40	18
HL4124A	1 ½	30	7	1750	400	28	200	14	350	175	40	18
HL4124B	1 ½	30	7	1750	400	28	200	14	350	175	40	18
AK124A	2	65	15	1450	400	28	200	14	450	230	82	37
AK4124A	2	65	15	1450	400	28	200	14	350	175	82	37
AK4124B	2	65	15	1450	400	28	200	14	350	175	78	35
AL124A	2	90	20	1450	400	28	200	14	450	230	85	39
AL4124A	2	90	20	1450	400	28	200	14	350	175	85	39
K124A	2	80	18	780	400	28	200	14	450	230	105	48
K1124A	2	80	18	780	400	28	200	14	225	105	110	50
K4124A	2	80	18	780	400	28	200	14	350	175	105	48
K4124B	2	80	18	780	400	28	200	14	350	175	105	48
KK124A	2	100	23	780	400	28	200	14	450	230	110	50
KK1124A	2	100	23	780	400	28	200	14	225	105	110	50
KK4124A	2	100	23	780	400	28	200	14	350	175	110	50
KK4124B	2	100	23	780	400	28	200	14	350	175	110	50
L124A	2	135	31	640	400	28	200	14	450	230	155	70
L124AE	2	135	31	640	400	28	200	14	450	230	155	70
L1124AE	2	135	31	640	400	28	200	14	225	105	147	67
L4124A	2	135	31	640	400	28	200	14	350	175	155	70
L4124AE	2	135	31	640	400	28	200	14	350	175	155	70
L4124B	2	135	31	640	400	28	200	14	350	175	155	70

① For maximum recommended discharge pressures at different viscosities, see performance curves, which can be electronically generated with the Viking Pump Curve Generator, located on www.vikingpump.com. If suction pressure exceeds 50 PSIG, consult factory. Higher pressures possible with factory approval based on application details.

② Extra clearances are required above 225°F / 105°C. Higher temperatures can be handled with special construction, consult factory.

③ Ports are tapped for standard (NPT) pipe. Other thread standards available. G through L ports are at 90°.

④ Maximum hydrostatic pressure for standard pump construction. Rating is dependent on seal, gaskets and ports.

Section	1401
Page	1401.8
Issue	F

UNIVERSAL PRODUCT LINE: CAST IRON — NON-JACKETED PUMPS

124A Series™, 124AE Series™, 1124A Series™, 1124AE Series™, 4124A Series™, 4124AE Series™, 4124B Series™, 324A Series™, 1324A Series™, 4324A Series™

SPECIFICATIONS – LQ, LL, LS, Q, QS, M, N, R, RS SIZES

Model Number	③ Standard Port Size	Nominal Pump Rating (100 SSU & below)			④ Maximum Hydrostatic Pressure		① Maximum Discharge Pressure for 100 SSU liquid at rated speed		② Maximum Recommended Temperature for Standard Pump		Approx. Shipping Weight with Valve	
	Inches	GPM	m ³ /h	RPM	PSIG	BAR	PSIG	BAR	°F	°C	Lbs.	Kg.
LQ124A	2 ½	135	31	640	300	21	200	14	450	232	175	80
LQ124AE	2 ½	135	31	640	300	21	200	14	450	232	175	80
LQ1124AE	2 ½	120	27	520	400	28	200	14	225	110	191	87
LQ4124A	2 ½	135	31	640	300	21	200	14	350	175	175	80
LQ4124AE	2 ½	135	31	640	300	21	200	14	350	175	175	80
LQ4124B	2 ½	135	31	640	300	21	200	14	350	175	175	80
LL124A	3	140	32	520	300	21	200	14	450	232	185	84
LL124AE	3	140	32	520	300	21	200	14	450	232	185	84
LL1124AE	3	140	32	640	400	28	200	14	225	110	199	90
LL4124A	3	140	32	520	300	21	200	14	350	175	185	84
LL4124AE	3	140	32	520	300	21	200	14	350	175	185	84
LL4124B	3	140	32	520	300	21	200	14	350	175	185	84
LS124A	3	200	45	640	300	21	200	14	450	232	190	86
LS1124A	3	200	45	640	400	28	200	14	225	110	228	103
LS4124A	3	200	45	640	300	21	200	14	350	175	190	86
LS4124B	3	200	45	640	300	21	200	14	350	175	190	86
Q124A	4	300	68	520	250	17	200	14	450	232	440	200
Q1124A	4	275	62	470	250	17	200	14	225	110	472	214
Q4124A	4	300	68	520	250	17	200	14	350	175	440	200
Q4124B	4	300	68	520	250	17	200	14	350	175	440	200
QS124A	6	500	114	520	250	17	200	14	450	232	540	245
QS1124A	6	400	91	470	250	17	200	14	225	110	507	230
QS4124A	6	500	114	520	250	17	200	14	350	175	540	245
QS4124B	6	500	114	520	250	17	200	14	350	175	540	245
M124A	4	420	95	420	250	17	200	14	450	232	600	272
M4124A	4	420	95	420	250	17	200	14	350	175	600	272
N324A	6	600	136	350	250	17	200	14	450	232	810	367
N1324A	6	535	122	330	250	17	200	14	225	110	937	425
N4324A	6	600	136	350	250	17	200	14	350	175	810	367
R324A	8	1100	250	280	250	17	200	14	450	232	1435	651
R1324A	8	915	208	225	250	17	200	14	225	110	1523	961
R4324A	8	1100	250	280	250	17	200	14	350	175	1435	651
RS324A	10	1600	364	280	250	17	125	8.5	450	232	2000	907
RS1324A	10	1300	295	255	250	17	125	8.5	225	110	1973	895
RS4324A	10	1600	364	280	250	17	125	8.5	350	175	2000	907

① For maximum recommended discharge pressures at different viscosities, see performance curves, which can be electronically generated with the Viking Pump Curve Generator, located on www.vikingpump.com. If suction pressure exceeds 50 PSIG, consult factory. Higher pressures possible with factory approval based on application details.

② Extra clearances are required above 225°F / 105°C. Higher temperatures can be handled with special construction, consult factory.

③ Flange ports are suitable for use with Class 125 ANSI cast iron companion flanges or flanged fittings.
LQ, LL, LS, Q & M ports are at 90°
QS, N, R and RS ports are at 180° (opposite)

④ Maximum hydrostatic pressure for standard pump construction. Rating is dependent on seal, gaskets and ports.

UNIVERSAL PRODUCT LINE: CAST IRON — NON-JACKETED PUMPS

124A Series™, 124AE Series™, 1124A Series™, 1124AE Series™, 4124A Series™, 4124AE Series™, 4124B Series™, 324A Series™, 1324A Series™, 4324A Series™

Section	1401
Page	1401.9
Issue	F

OPTIONAL CASINGS

Size	Standard Casings		Optional Casings						
	Ports (Inches)	Rotatable Data							
G	1.5"①®	Fully Rotatable	1.5"②®	1.5"③®	2"②®				
H	1.5"①®	Fully Rotatable	1.5"②®	1.5"③®	2"②®				
HL	1.5"①®	Fully Rotatable	1.5"②®	1.5"③®	2"②®				
AK	2"①®	Fully Rotatable							
AL	2"①®	Fully Rotatable							
K	2"①®	Fully Rotatable	2"②®	2"③®	2.5"①⓪	2.5"②®	3"②®	4"②®	
KK	2"①®	Fully Rotatable	2"②®	2"③®	2.5"①⓪	2.5"②®	3"②®	4"②®	
L	2"①®	Fully Rotatable							
LQ	2.5"②®	Ports cannot face down	2.5"③®	3"②®	4"②®	6"②®*	Side 5"②®, Top 6"②		
LL	3"②®	Fully Rotatable	3"③®	4"②®	5"②®*				
LS	3"②®	Fully Rotatable	3"③®	4"②®*					
Q	4"②®	Fully Rotatable	4"③®	3"②®	5"②®	6"②⓪	Side 4"②®, Top 8"②	Side 4"②⓪, Top 8"②	Side 6"②®, Top 8"②
QS	6"②⓪	Rotatable with special casing	6"②®						
M	4"②®	Fully Rotatable	6"②®	6"②⓪					
N	6"②⓪	Not Rotatable	5"②⓪	6"②⓪					
R	8"②⓪	Not Rotatable	6"②⓪						
RS	10"②⓪	Not Rotatable	10"②						

① Port(s) tapped for standard (NPT) pipe.

② Port(s) suitable for use with Class 125 ANSI cast iron companion flanges or flanged fittings.

③ Port(s) suitable for use with Class 250 ANSI cast iron companion flanges or flanged fittings.

⓪ 90° port arranged for Left Hand inlet (viewed from shaft end)

Ⓝ Non-Rotatable Ports at 90° angle, contact factory for available orientation (right hand or left hand)

⓪ Opposite Ports

® 90° port arranged for Right Hand inlet (viewed from shaft end)

* Core smaller than port size

Section	1401
Page	1401.10
Issue	F

UNIVERSAL PRODUCT LINE: CAST IRON — NON-JACKETED PUMPS

124A Series™, 124AE Series™, 1124A Series™, 1124AE Series™, 4124A Series™, 4124AE Series™, 4124B Series™, 324A Series™, 1324A Series™, 4324A Series™

DIMENSIONS – G, H, HL, AK, AL, K, KK, L, LQ, LL, LS, Q, M SIZES

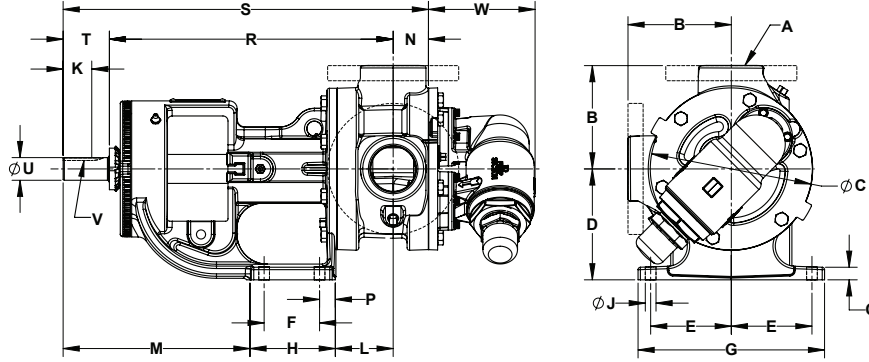

These dimensions are average and not for construction purposes. Certified prints on request.

NOTE: Dimensions "N" through "W" on next page

Model Number			A (in)		B	C	D	E	F	G	H	J	K	L	M
Packed	O-Pro™ Seal	Mechanical Seal													
G124A		G4124A G4124B	① 1	in	2.50	3.66	2.75	1.62	1.31	4.00	2.38	0.34	0.57	1.21	4.87
				mm	64	93	70	41	33	102	60	9	14	31	124
H124A HL124A	H1124A HL1124A	H4124A H4124B HL4124A HL4124B	① 1.5	in	3.00	4.75	3.50	2.75	2.25	6.75	3.50	0.47	0.99	3.38	5.19
				mm	76	121	89	70	57	171	89	12	25	86	132
AK124A AL124A		AK4124A AL4124A AK4124B	① 2	in	4.50	6.75	5.25	2.88	2.00	6.75	4.03	0.41	1.67	2.82	8.84
				mm	114	171	133	73	51	171	102	10	42	72	225
K124A KK124A	K1124A KK1124A	K4124A K4124B KK4124A KK4124B	① 2	in	5.12	8.00	5.50	4.00	2.75	9.25	4.00	0.53	1.42	3.00	9.38
				mm	130	203	140	102	70	235	102	13	36	76	238
L124A L124AE	L1124AE	L4124A/AE L4124B	① 2	in	6.50	10.25	7.00	4.38	4.00	10.00	5.38	0.53	1.42 ④	3.38	9.12
				mm	165	260	178	111	102	254	137	13	36 ④	86	232
LQ124A LQ124AE	LQ1124AE	LQ4124A/AE LQ4124B	② 2.5	in	7.19	10.25	7.00	4.38	4.00	10.00	5.38	0.53	1.42 ④	3.38	9.12
				mm	183	260	178	111	102	254	137	13	36 ④	86	232
LL124A LL124AE	LL1124AE	LL4124A/AE LL4124B	② 3	in	7.19	10.25	7.00	4.38	4.00	10.00	5.38	0.53	1.42 ④	3.38	9.12
				mm	183	260	178	111	102	254	137	13	36 ④	86	232
LS124A	LS1124A	LS4124A LS4124B	② 3	in	7.19	10.25	7.00	4.38	4.00	10.00	5.38	0.53	2.55	4.75	9.12
				mm	183	260	178	111	102	254	137	13	65	121	232
Q124A	Q1124A	Q4124A Q4124B	② 4	in	8.25	14.00	8.75	4.12	4.00	10.00	6.00	0.69	3.58	6.62	11.12
				mm	210	356	222	105	102	254	152	18	91	168	282
M124A		M4124A	② 4	in	9.50	17.35	10.00	5.00	6.00	12.00	8.53	0.69	3.50	7.75	8.10
				mm	241	441	254	127	152	305	217	18	89	197	206

① Ports are tapped for standard (NPT) pipe. Other thread standards available.

② Ports are suitable for use with Class 125 ANSI cast iron.

③ Ports are suitable for Class 150 ANSI steel or stainless steel companion flanges or flanged fittings.

④ "K" dimension for L, LQ & LL sizes is for "A" and "B" models. "K" dimension for L, LQ & LL size "AE" models is 1.30" (33.0 mm).

UNIVERSAL PRODUCT LINE: CAST IRON — NON-JACKETED PUMPS

124A Series™, 124AE Series™, 1124A Series™, 1124AE Series™, 4124A Series™, 4124AE Series™, 4124B Series™, 324A Series™, 1324A Series™, 4324A Series™

Section	1401
Page	1401.11
Issue	F

DIMENSIONS – G, H, HL, AK, AL, K, KK, L, LQ, LL, LS, Q, M SIZES (CONT'D)

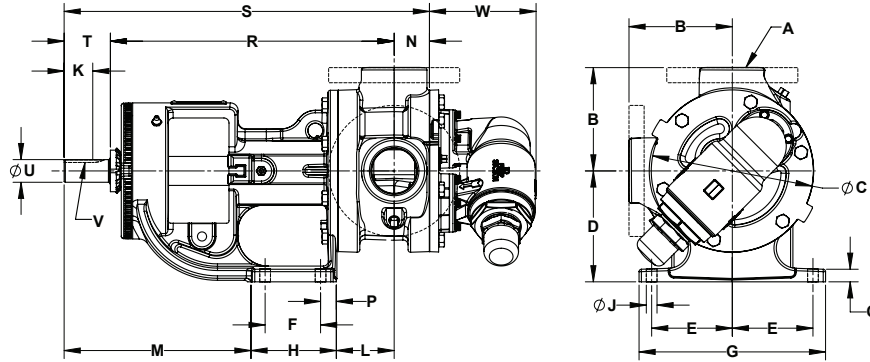

These dimensions are average and not for construction purposes. Certified prints on request.

NOTE: Dimensions "A" through "M" on previous page

Model Number				N	O	P	R	S	T	U (in)	V (in)	W
Packed	O-Pro™ Seal	Mechanical Seal										
G124A		G4124A	in	1.09	0.31	0.63	7.40	9.55	1.06	0.50	.12 x .06	2.71
		G4124B	mm	28	8	16	188	143	27			
H124A HL124A	H1124A HL1124A	H4124A	in	1.19	0.56	0.62	10.44	13.25	1.62	0.75	.19 x .09	2.85
		H4124B HL4124A HL4124B	mm	30	14	16	265	337	41			
AK124A AL124A		AK4124A	in	2.00	0.44	1.00	13.19	17.69	2.50	1.00	.25 x .12	4.83
		AL4124A AK4124B	mm	51	11	25	335	449	64			
K124A KK124A	K1124A KK1124A	K4124A	in	1.75	0.62	0.62	14.12	18.12	2.25	1.12	.25 x .12	5.25
		K4124B KK4124A KK4124B	mm	44	16	16	359	460	57			
L124A		L4124A	in	1.75	0.62	0.62	15.62	19.62	2.25	1.12	.25 x .12	5.43
			mm	44	16	16	397	498	57			
L124AE	L1124AE	L4124AE	in	1.75	0.62	0.62	15.62	19.62	2.35	1.44	.38 x .19	5.43
		L4124B	mm	44	16	16	397	498	60			
LQ124A		LQ4124A	in	1.75	0.62	0.62	15.62	19.62	2.25	1.12	.25 x .12	5.43
			mm	44	16	16	397	498	57			
LQ124AE	LQ1124AE	LQ4124AE	in	1.75	0.62	0.62	15.62	19.62	2.35	1.44	.38 x .19	5.43
		LQ4124B	mm	44	16	16	397	498	60			
LL124A		LL4124A	in	2.25	0.62	0.62	15.62	20.12	2.25	1.12	.25 x .12	5.43
			mm	57	16	16	397	511	57			
LL124AE	LL1124AE	LL4124AE	in	2.25	0.62	0.62	15.62	20.12	2.35	1.44	.38 x .19	5.43
		LL4124B	mm	57	16	16	397	511	60			
LS124A	LS1124A	LS4124A	in	2.44	0.62	0.62	15.75	21.69	3.50	1.44	.38 x .19	5.43
		LS4124B	mm	62	16	16	400	551	89			
Q124A	Q1124A	Q4124A	in	3.00	0.8	1.00	19.25	26.75	4.50	1.94	.50 x .25	8.25
		Q4124B	mm	76	20	25	489	679	114			
M124A		M4124A	in	4.00	1.00	1.52	20.13	28.38	4.25	1.94	.50 x .25	8.61
			mm	102	25	39	511	721	108			

Section	1401
Page	1401.12
Issue	F

UNIVERSAL PRODUCT LINE: CAST IRON — NON-JACKETED PUMPS

124A Series™, 124AE Series™, 1124A Series™, 1124AE Series™, 4124A Series™, 4124AE Series™, 4124B Series™, 324A Series™, 1324A Series™, 4324A Series™

DIMENSIONS – QS SIZE

Dimensions shown in inches with millimeter equivalent shown in parentheses

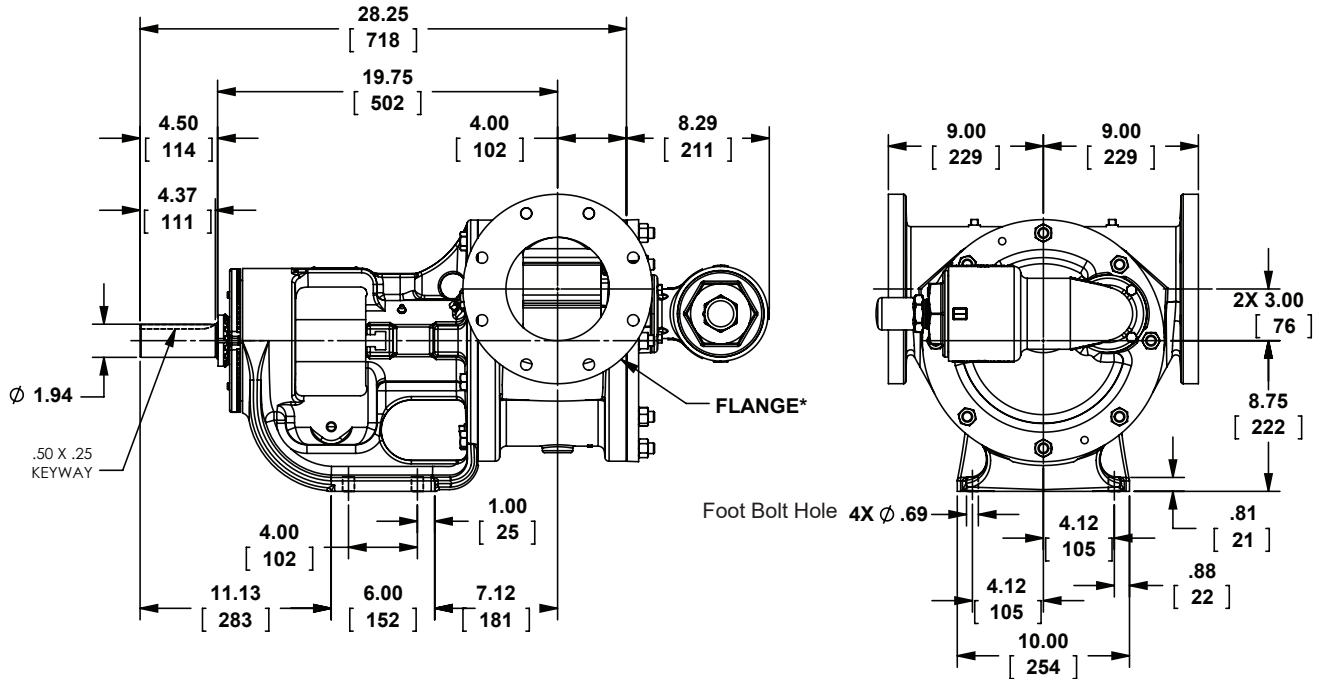

* 124A Series™, 1124A Series™, 4124A Series™ ports suitable for use with Class 125 ANSI cast iron companion flanges or flanged fittings.

NOTE: Flanges are 6", suitable for use with Class 125 ANSI cast iron companion flanges or flanged fittings. They are studded, not through-bolt.

UNIVERSAL PRODUCT LINE: CAST IRON — NON-JACKETED PUMPS

124A Series™, 124AE Series™, 1124A Series™, 1124AE Series™, 4124A Series™, 4124AE Series™, 4124B Series™, 324A Series™, 1324A Series™, 4324A Series™

Section	1401
Page	1401.13
Issue	F

DIMENSIONS – N, R, RS SIZES – JACKETED BRACKET (324A SERIES™, 1324A SERIES™, 4324A SERIES™)

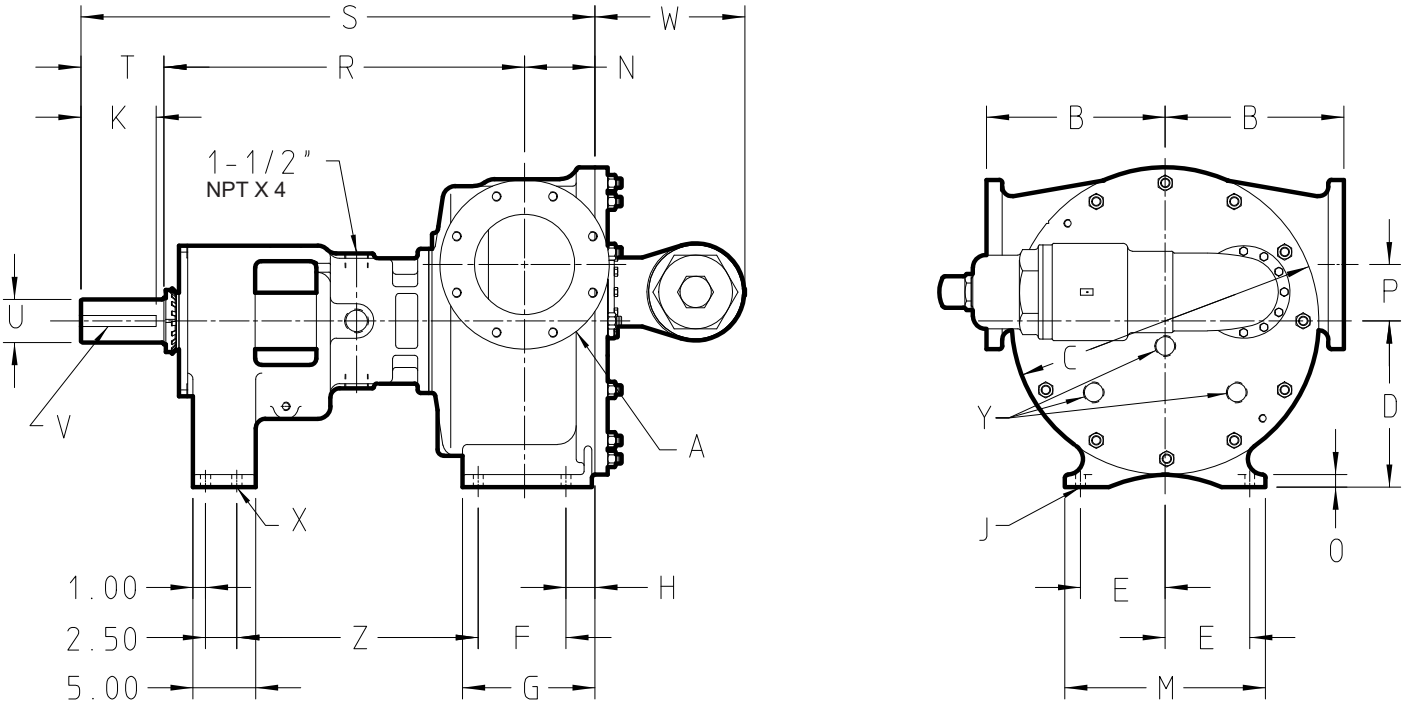

Model Number			A	B	C	D	E	F	G	H	J	K	M	N	
Packed	O-Pro™ Seal	Stuffing Box Seal	(in)												
N324A	N1324A	N4324A	① 6	in	9.75	17.25	9.50	5.00	6.25	8.69	1.62	0.69	4.50	12.00	4.50
				mm	248	438	241	127	159	221	41	18	114	305	114
R324A	R1324A	R4324A	① 8	in	14.25	24.50	13.25	6.75	7.00	10.56	2.31	0.78	6.00	16.00	5.62
				mm	362	622	337	171	178	268	59	20	152	406	143
RS324A	RS1324A	RS4324A	① 10	in	14.25	24.5	13.25	6.75	7.00	13.12	4.81	0.88	6.00	16.46	8.12
				mm	362	622	337	171	178	333	122	22	152	418	206

Model Number			O	P	R	S	T	U (in)	V (in)	W	X	Y	Z	
Packed	O-Pro™ Seal	Stuffing Box Seal												
N324A	N1324A	N4324A	in	1.00	3.00	26.00	36.50	6.00	2.44	.62 x .31	8.63	0.69	—	18.94
			mm	25	76	660	927	152			219	18	—	481
R324A	R1324A	R4324A	in	1.00	4.50	28.75	41.00	6.62	3.44	.88 x .44	12.00	0.69	1.25	19.25
			mm	25	114	730	1041	168			305	18	32	489
RS324A	RS1324A	RS4324A	in	1.30	4.50	28.55	43.49	6.62	3.44	.88 x .44	—	0.88	1.25	19.25
			mm	33	114	725	1105	168			—	22	32	489

① Ports are suitable for use with Class 125 ANSI cast iron (324A Series™/4324A Series™)

NOTE: The N size is standard with a jacketed bracket and non-jacketed head and non-jacketed relief valve, while the “R” size is standard with a jacketed bracket, a jacketed head, and a non-jacketed relief valve. “RS” contact factory for jacketing options.

RS relief valve not available. Contact factory for options.

Section	1401
Page	1401.14
Issue	F

UNIVERSAL PRODUCT LINE: CAST IRON — NON-JACKETED PUMPS

124A Series™, 124AE Series™, 1124A Series™, 1124AE Series™, 4124A Series™, 4124AE Series™, 4124B Series™, 324A Series™, 1324A Series™, 4324A Series™

DIMENSIONS – STUFFING BOX SEAL CHAMBER (EXCEPT 4124B SERIES™)

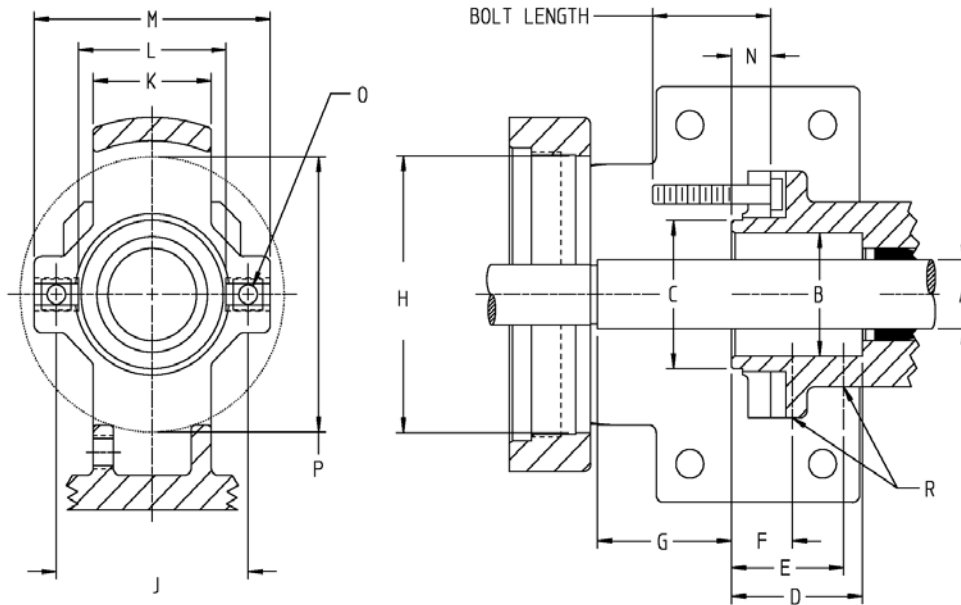

Pump Size		A	B	C	D	E	F	G	H	J	K	L	M	N	O	P	R
G	In	0.75	1.63	2.12	1.91	1.38	0.57	1.72	3.87	2.74 to 3.12	1.64	2.24	3.62	1.00	5/16	3.87	1/8
	mm		41	54	49	38	15	44	98	70 to 79	42	57	92	25		98	3
H & HL	In	1.12	2.00	2.41	2.22	1.90	1.03	2.27	4.50	3.00 to 3.50	2.00	2.50	4.00	0.66	5/16	4.47	1/8
	mm		51	61	56	48	26	58	114	76 to 89	51	64	102	17		114	3
AK & AL	In	1.44	2.31	2.69	2.75	2.25	1.24	3.03	5.25	3.14 to 4.56	2.50	3.00	5.00	0.47	7/16	6.15	1/4
	mm		59	68	70	57	32	77	133	80 to 116	64	76	127	12		156	6
K & KK	In	1.44	①2.31	3.00	3.13	2.25	1.25	3.00	5.25	3.50 to 4.50	2.50	3.00	5.00	0.38	7/16	5.25	1/4
	mm		①58.7	76	80	57	32	76	133	89 to 114	64	76	127	10		133	6
L, LQ, & LL (A)	In	1.44	①2.31	3.00	3.13	2.25	1.25	4.00	5.25	3.50 to 4.50	2.50	3.00	5.00	0.44	7/16	5.25	1/4
	mm		①58.7	76	80	57	32	102	133	89 to 114	64	76	127	11		133	6
L, LQ, & LL (AE)	In	1.62	2.38	3.00	3.13	2.25	1.16	3.52	5.25	3.50 to 4.50	3.00	3.00	5.00	0.46	7/16	5.25	1/4
	mm		60	76	80	57	30	89	133	89 to 114	76	76	127	12		133	6
LS	In	1.62	2.38	2.80	2.70	2.25	1.16	3.52	5.25	3.25 to 4.50	3.00	2.80	5.00	0.46	7/16	5.25	1/4
	mm		60	71	69	57	30	89	133	83 to 114	76	71	127	12		133	6
Q & QS ③	In	2.44	3.42	4.50	4.00	2.50	1.53	4.10	6.75	5.50 to 6.25	3.20	4.50	7.20	0.56	5/8	6.75	1/4
	mm		87	114	102	64	39	104	171	140 to 159	81	114	183	14		171	6
M	In	2.44	3.44	—	3.97	2.50	1.53	4.16	6.75	5.44 to 6.26	3.28	4.50	7.20	0.72	5/8	7.37	1/4
	mm		87	—	101	64	39	106	171	138 to 159	83	114	183	18		187	6
N	In	3.44	4.69	—	5.56	1.65	—	4.91	8.81	6.75	—	—	—	—	②3/4	9.00	1/4
	mm		119	—	141	42	—	125	224	171	—	—	—	—		229	6
R & RS	In	4.50	5.75	—	5.56	1.53	—	4.79	9.81	7.75	—	—	—	—	②3/4	9.81	1/4
	mm		146	—	141	39	—	122	249	197	—	—	—	—		249	6

① Bracket is counter bored to a diameter of 2.687 inches (68 mm), 0.12 inches (3 mm) deep from stuffing box face.

② Studs are used in place of cap screws.

③ For Q, QS size brackets, seal box dimensions differ between O-Pro™ Barrier and traditional seal options. Consult factory for options.

UNIVERSAL PRODUCT LINE: CAST IRON — NON-JACKETED PUMPS

124A Series™, 124AE Series™, 1124A Series™, 1124AE Series™, 4124A Series™, 4124AE Series™, 4124B Series™, 324A Series™, 1324A Series™, 4324A Series™

Section	1401
Page	1401.15
Issue	F

NPSH REQUIRED

Printed performance curves are not available.

Performance curves can be electronically generated with the Viking Pump Curve Generator on vikingpump.com.

NPSHR data is not available on the pump selector.

NPSH (Net Positive Suction Head): The $NPSH_R$ (Net Positive Suction Head Required by the pump) is given in the table below and applies for viscosities through 750 SSU. $NPSH_A$ (Net Positive Suction Head – Available in the system) must be greater than the $NPSH_R$. For a complete explanation of NPSH, see Application Data Sheet AD-19.

FOR VISCOSITIES UP TO 750 SSU – See $NPSH_R$ table below.

$NPSH_R$ for high viscosities can be estimated using the following method:

1. Calculate line loss for a 1 foot long pipe of a diameter matching the pump inlet port size. Use your flow rate and max viscosity.
2. Convert this value into Feet of Liquid (S.G. 1.0)
3. Add this value to the $NPSH_R$ value in the chart below.

PUMP SIZE	PUMPS SPEED, RPM														
	100	125	155	190	230	280	350	420	520	640	780	950	1150	1450	1750
G	—	—	—	—	—	—	—	1.8	2.0	2.2	2.6	3.1	3.9	5.6	7.6
H, HL	—	—	—	—	1.7	1.8	1.9	2.1	2.4	2.8	3.4	4.5	6.2	9.5	13.5
AK, AL	—	—	1.6	1.7	1.8	2.0	2.3	2.7	3.2	3.9	5.5	7.7	11.2	—	—
K, KK	—	1.7	1.8	1.9	2.1	2.3	2.8	3.3	4.4	6.3	9.1	—	—	—	—
L	1.6	1.8	2.0	2.2	2.5	3.0	3.8	5.0	7.3	10.8	—	—	—	—	—
LQ	1.6	1.8	2.0	2.2	2.5	3.0	3.8	5.0	7.3	10.8	—	—	—	—	—
LL	1.6	1.8	2.0	2.2	2.5	3.0	3.8	5.0	7.3	—	—	—	—	—	—
LS	1.6	1.8	2.0	2.2	2.5	3.0	3.8	5.0	7.3	10.8	—	—	—	—	—
Q, QS	1.9	2.1	2.3	2.7	3.3	4.2	6.1	8.4	12.7	—	—	—	—	—	—
M	2.1	2.3	2.8	3.4	4.3	6.0	9.0	12.7	—	—	—	—	—	—	—
N	2.1	2.3	3.5	4.5	6.3	9.5	15.0	—	—	—	—	—	—	—	—
R	6.1	7.1	8.3	10.1	12.1	15.2	—	—	—	—	—	—	—	—	—
RS	7.0	8.5	10.4	13.1	17.2	22.4	—	—	—	—	—	—	—	—	—

$NPSH_R$ – FEET OF LIQUID (Specific Gravity 1.0), Viscosities up to 750 SSU